

# OPERATION AND MAINTENANCE MANUAL FOR 3670x50 SERIES SEMI-RIGID CABLES

## 1. INTRODUCTION

This manual describes the 3670x50 series semirigid cables (Figure 1). It provides specifications, performance verification instructions, and a list of precautions the user should observe when using these cables.

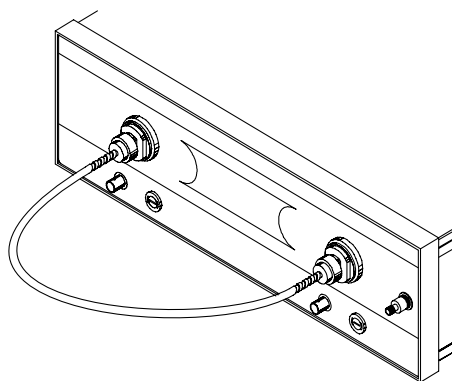

**Figure 1.** Typical 3670x50 Series Semi-rigid Cable

## 2. DESCRIPTION

The 3670x50 series cables are laboratory quality cables that contain General Precision Connectors (GPC). The model number of each cable in the series is listed in Table 1 with connector type and frequency range. These cables are used to connect VNA test sets to the device under test (DUT). They are also used to connect to a 3680 Universal Test Fixture or other test interface device.

## 3. SPECIFICATIONS

Table 1 lists the performance specifications for these cables.

## 4. PRECAUTIONS

ANRITSU series 3670x50 cables are precision laboratory items and should receive the same care and respect afforded other such equipment. Complying with the following precautions will guarantee longer cable life and less equipment downtime due to connector failure. Also, such compliance will ensure that cable component failures are not due to misuse or abuse—two failure modes not covered under the ANRITSU warranty.

**Table 1.** 3670x50 Series Specifications

Model	Length (Feet)	Frequency Range (GHz)	Connector Type	Return Loss
3670N50-1 <sup>(1)</sup>	1	DC to 18	Type N Female to Type N Male	17 dB min.
3670N50-2	2			
3670NN50-1 <sup>(1)</sup>	1	DC to 18	Type N Male to Type N Male	17 dB min.
3670NN50-2	2			
3670A50-1 <sup>(1)</sup>	1	DC to 18.5	GPC-7 to GPC-7	17 dB min.
3670A50-2	2			
3670K50-1 <sup>(1)</sup>	1	DC to 40	K Connector <sup>®</sup> Female to K Connector <sup>®</sup> Male	16 dB min.
3670K50-2	2			
3670V50-1 <sup>(1)</sup>	1	DC to 65	V Connector <sup>®</sup> Female to V Connector <sup>®</sup> Male	16 dB min.
3670V50-2 <sup>(2)</sup>	2			
3670V50A-1 <sup>(1)</sup>	1	DC to 70	V Connector <sup>®</sup> Female to V Connector <sup>®</sup> Male	16 dB min.
3670V50A-2 <sup>(2)</sup>	2			

1. Two required.

2. This cable replaces 1.5 ft. cable (3670V50-1.5).

K Connector and V Connector are registered trademarks of the ANRITSU Company.

- a. **Bend Cables Carefully.** Never bend the cable sharply. Use gentle radius bends only. Place bends in the center portion of cable; never bend near the connectors. Avoid twisting cable; loosen and retighten connectors, if necessary.
- b. **Beware of Destructive Pin Depth of Mating Connectors.** Measure the center conductor depth of DUT connectors that mate with 3670x50 cable connectors, *before* mating. Use an ANRITSU Pin Depth Gauge (Figure 2), or equivalent. Based on RF components returned for repair, destructive center conductor depth of mating connectors is the major cause of failure in the field. When a 3670x50 cable connector is mated with another connector having a destructive pin depth, damage will likely occur to the cable connector.

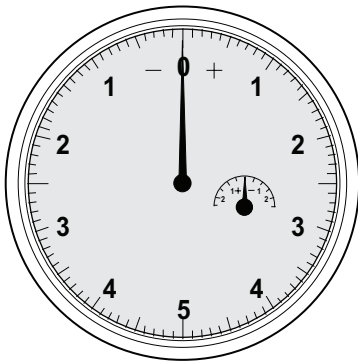

Figure 2. Pin Depth Gauge Scale

(A destructive pin depth has a center conductor that is too long in respect to the reference plane of the connector.)

The center conductor depth of 3670x50 cable connectors have a tolerance measured in mils (1/1000 inch). Test device connectors that mate with these cables may not be precision types and may not have the proper center conductor depth. *They must be measured before mating to ensure suitability.* If the test device center conductor is too long, it will measure out of tolerance in the “+” region (Table 2). *Mating under this condition will possibly damage the cable center conductor.* If the test device center conductor is too short it will measure out of tolerance in the “-” region.

This condition will not cause damage; however, it may result in a poor connection and result in a degradation of performance.

Table 2. Allowable Mating Connector Pin Depth

Connector Pin	Depth Type (Inches)
GPC-7	+0.000 to -0.003
K	+0.000 to -0.005
V	+0.000 to -0.004
N Male	-0.207 to -0.227
N Female	+0.207 to +0.187

- c. **Avoid Over Torquing Connectors.** Over torquing connectors is destructive; it may damage the connector center pins. Always use a connector torque wrench when tightening GPC and other precision type connectors. (The wrench should be set to 8 inch-pounds maximum.) *Never* use pliers.
- d. **Avoid Mechanical Shock.** Do not drop or otherwise treat 3670x50 cables roughly. Mechanical shock or rough handling will decrease the useful life of these cables. Avoid introducing a bend radius of less than 3 inches.
- e. **Keep Cable Connectors Clean.** The precise geometry of the precision connectors that makes the high performance of these cables possible can be easily disturbed by dirt and other contamination adhering to connector interfaces. When not in use, keep the connectors covered. Refer to section 7 for cleaning instructions.

## 5. CONNECTING AND USING CABLES

Connect the female connector of one 3670x50 cable to the Port 1 connector of the test set. Repeat for Port 2 with the second cable (if used). When connecting cables, use a connector torque wrench and observe all other precautions described above.

## 6. PERFORMANCE VERIFICATION

Performance verification consists of measuring the pin depth of the cable connectors and measuring return loss of each cable.

- a. **Pin Depth Measurement.** Gauges for measuring the pin depth of GPC-7, K, and V type connectors are located in the Model 365X calibration kits available from ANRITSU. Instructions for using these gauges are provided with each set. The pin depth specifications for each cable model are listed in Table 3 on the following page.

**Table 3.** 3670x50 Series Connector Pin Depth

Model	Connector Type	Pin Depth (Inches)
3670A50 (-1 & -2)	GPC-7	-0.0000 to -0.001
3670K50 (-1 & -2)	K Connector®	-0.0000 to -0.001
3670V50 (-1 & -2)	V Connector®	-0.0000 to -0.0040
3670V50A (-1 & -2)	V Connector®	-0.0000 to -0.0040
3670N50 (-1 & -2)	N Male	-0.207 to -0.227
3670NN50 (-1 & -2)	N Female	0.207 to 0.187

**b. Return Loss Measurement.** To measure the return loss of 3670x50 series cables, proceed as follows:

1. Perform a reflection only VNA calibration with the cables disconnected. Use a sliding load when performing this calibration. (Refer to the Vector Network Analyzer Operation Manual.)
2. Connect cable to be checked. Terminate cable with a precision termination (the return loss of the termination used for this test must be 30 dB or greater).
3. Perform a return loss measurement over the operating frequency for the cable (see Table 1).
4. Verify that return loss is within specifications listed in Table 1.
5. Repeat for second cable (if used).

## 7. MAINTENANCE

It is recommended that no maintenance other than cleaning be attempted by the customer. Series 3670x50 cables should be returned to ANRITSU for repair and/or service when needed.

To clean the connector interfaces, use a clean cotton swab that has been *dampened* with denatured alcohol. Proper techniques for cleaning male and female connectors are shown in Figure 3 on the next page and listed below.

- Always use denatured alcohol as cleaning solvent. Never use industrial solvent or water, as damage to the connectors may result.
- Never put lateral pressure on the center pin of the connector.
- Verify that no cotton or other foreign material remains in the connector after cleaning it.
- If available, use compressed air to remove foreign particles and to dry the connector.
- After cleaning, verify that the center pin has not been bent or damaged.

### Note

Most cotton swabs are too large to fit into the ends of the smaller connector types. In these cases it is necessary to peel off most of the cotton and then twist the remaining cotton tight. Be sure that the remaining cotton does not get stuck in the connector.

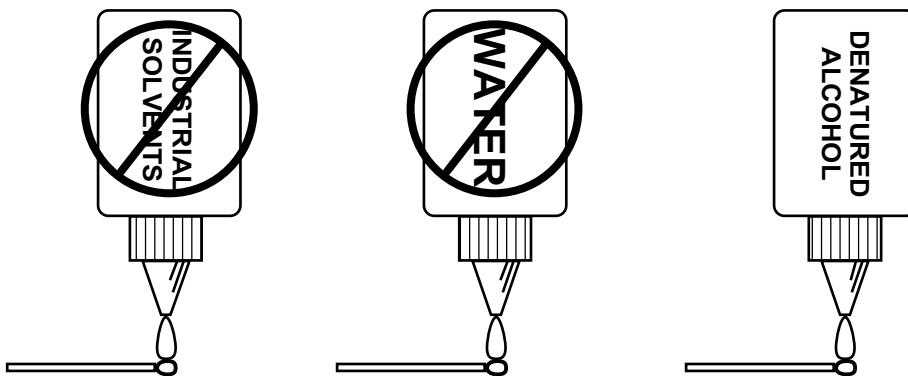

Do NOT use Industrial Solvents or Water on connector. Use only Denatured Alcohol.

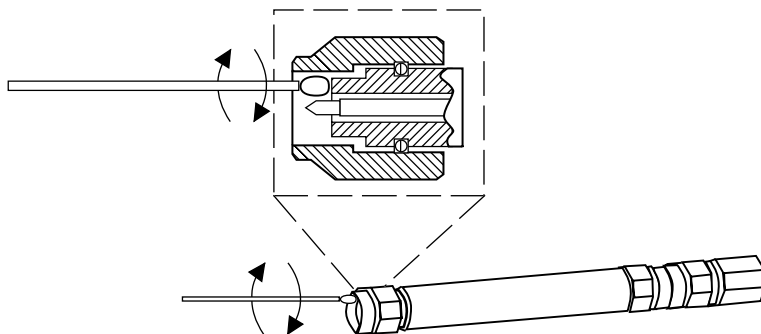

Use only denatured alcohol and the proper size of cotton swab. Gently rotate the swab around the center pin being careful not to stress or bend the pin or you will damage the connector.

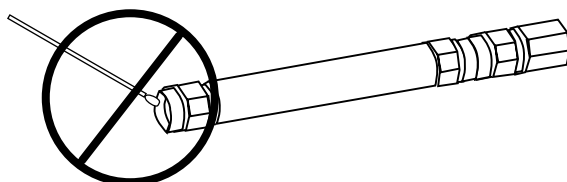

Do NOT put cotton swabs in at an angle, or you will damage the connectors.

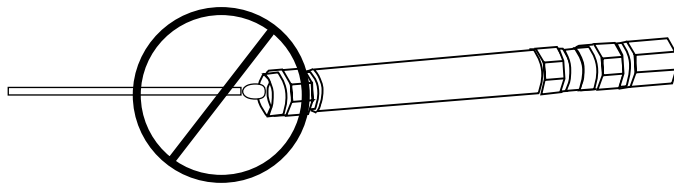

Do NOT use too large of cotton swab, or you will damage the connectors.

**Figure 3.** Cleaning Males and Female GPC Type Connectors